



# FLAIL MOWERS

**REAR, FRONT  
EXTENSION ARMS AND ATTACHMENTS**



**Over 70 models**  
of machines for summer  
road maintenance

**TABLE OF CONTENTS:**

	<b>PAGE</b>
<b>PIKO</b> REAR - FRONT LIGHT CLASS	6
<b>NANO 150 HYDRO</b> REAR - FRONT LIGHT CLASS	7
<b>Electrophoretic cathode metal coating (E-COAT)</b>	8
<b>MIDO</b> REAR - FRONT MEDIUM CLASS	9
<b>VINO</b> REAR - FRONT MEDIUM CLASS	10
<b>KANGU</b> REAR - BACK-SIDE PANTOGRAPH MEDIUM CLASS	11
<b>KBRP</b> REAR - BACK-SIDE PANTOGRAPH HEAVY CLASS	12 - 13
<b>GRINO</b> REAR - FRONT MEDIUM CLASS	14 - 15
<b>MAMUT</b> REAR - FRONT SUPER HEAVY DUTY CLASS	16 - 17
<b>MAMUT 860 TWIN</b> REAR - TWO SIDED SUPER HEAVY DUTY CLASS	18
<b>KBR L</b> REAR-SIDED LIGHT CLASS	19
<b>IBIS</b> REAR SELF-COLLECTING FLAIL MOWERS LIGHT CLASS	20 -21
<b>KOLIBER</b> EXTENSION ARM REAR + ATTACHMENTS	22 - 23
<b>KWT</b> EXTENSION ARM REAR + ATTACHMENTS	24 - 25
<b>Camel 900</b> EXTENSION ARM REAR + ATTACHMENTS	26 - 27
<b>MOWING HEADS</b> EXTENSION ARM REAR + ATTACHMENTS	28 - 31
<b>TECHNICAL DATA</b>	32 - 35

Roads are undoubtedly the bloodstream of the modern economy. Inscribed in the landscape of green areas, cultivated meadows and pastures, they create an infrastructure including space for municipal machinery - modern “robots”. These robots are designed for effective maintenance and care, which translates into measurable benefits.

SaMASZ municipal machines have been designed to meet the customers’ needs, taking into account the latest technologies and trends. The reliable and versatile machines ensure efficient operation even in the toughest conditions. A wide range of machines allows you to customise them to your needs.

Convenience and ease of use, as well as the ease of configuration improve the working comfort. The machines meet the highest quality standards. Thanks to effective warranty and post-warranty service, as well as the availability of spare parts, which is highly valued by the customers, SaMASZ boasts 39 years of being a reliable partner of many municipal companies and farms.

**Electrophoretic cathode metal coating (E-COAT) - the way for a long surface life**

- high quality of the coating
- covering complex shapes
- precise control of the coating thickness
- corrosion protection
- chemical protection
- mechanical protection



# Flail mowers

general characteristics



Flail mowers – mulchers are designed for general maintenance of lawns, orchards or pastures as well as carriageway grass maintenance. These machines are used to mulch straw, thicket and bushes (up to 8 cm / 3 1/5") and cut weed on un-

developed areas with intention to leave the swath spread. Mulcher's main task is to cut the grass and spread it properly crumbled along the whole width of the cut surface. It enables forming a natural swath and plant offcuts mineralization.

# Flail knives

ALPINA 300



### FLAIL MOWERS - MULCHERS

#### LIGHT CLASS (PIKO • LAMA • NANO HYDRO • IBIS)

1. Flail shaft diameter -  $\varnothing 108$  (4 1/4") mm, wall thickness 6,3 mm (1/5")  
 2. Mulching shrubs and bushes (up to 3,5 cm - 1 2/5" diameter depends on knife type),  
 3. Ground following bar -  $\varnothing 108$ -133 mm (4 1/4" or 5 1/4"),

#### MEDIUM CLASS (MIDO • KANGU • KW • VINO)

1. Flail shaft diameter -  $\varnothing 133$  (5 1/5")-168 mm (6 3/5"), wall thickness 8,8 mm (2/5") - 10 mm (2/5")  
 2. Mulching shrubs and bushes (up to 6 cm diameter depends on knife type)  
 3. Ground following bar -  $\varnothing 133$  (5 1/5") - 168 mm (6 3/5")

#### HEAVY CLASS (GRINO • KBRP)

1. Flail shaft diameter -  $\varnothing 168$  mm (6 3/5"), wall thickness 8,8 mm / 2/5"  
 2. Cutting shrubs and bushes (up to 7 cm - 3 1/5")  
 3. Ground following bar -  $\varnothing 168$  (6 3/5").

#### SUPER HEAVY CLASS (MAMUT)

1. Flail shaft diameter -  $\varnothing 203$  mm (8"), wall thickness 10 mm / 2/5"  
 2. Mulching shrubs and bushes (up to 8 cm - 3 1/5")  
 3. Ground following bar -  $\varnothing 203$  (8")

 <b>KNIFE TYPE I</b> Max. diameter of branches to be cut: $\varnothing 80$ mm (3 1/5"), Width: 140 mm, Length: 98 mm. ~ 1,2 kg (2,65 lbs)	 <b>KNIFE TYPE II</b> Max. diameter of branches to be cut: $\varnothing 35$ mm (1 2/5"), Width: 104 mm (2x 52 mm), Length: 120 mm. ~ 0,6 kg (1,3 lbs)	 <b>KNIFE TYPE III</b> Max. diameter of branches to be cut: $\varnothing 35$ mm (1 2/5"), Width: 104 mm, Length: 120 mm. ~ 1,0 kg (2,2 lbs)	 <b>KNIFE TYPE VII</b> Max. diameter of branches to be cut: $\varnothing 20$ mm (4/5"), Width: 68 mm, Length: 73 mm. ~ 0,2 kg (0,45 lbs)
 <b>KNIFE TYPE IV</b> Max. diameter of branches to be cut: $\varnothing 35$ mm (1 2/5"), Width: 102 mm, Length: 115 mm. ~ 1,0 kg (2,2 lbs)	 <b>KNIFE TYPE V</b> Max. diameter of branches to be cut: $\varnothing 50$ mm (2"), Width: 100 mm, Length: 105 mm. ~ 0,6 kg (1,3 lbs)	 <b>KNIFE TYPE VI</b> Max. diameter of branches to be cut: $\varnothing 80$ mm (3 1/5"), Width: 120 mm, Length: 110 mm. ~ 1,4 kg (3,1 lbs)	 <b>KNIFE TYPE VIII</b> Max. diameter of branches to be cut: $\varnothing 20$ mm (4/5"), Width: 84 mm (2x 42 mm), Length: 82 mm. ~ 0,3 kg (0,65 lbs)
 <b>KNIFE TYPE X</b> Max. diameter of branches to be cut: $\varnothing 35$ mm (1 2/5"), Width: 62 mm, Length: 62 mm. ~ 0,3 kg (0,65 lbs)	 <b>KNIFE TYPE XI</b> Max. diameter of branches to be cut: $\varnothing 15$ mm (0,6"), Width: 72 mm, Length: 88 mm. ~ 0,2 kg (0,45 lbs)	 <b>KNIFE TYPE IX</b> Max. diameter of branches to be cut: $\varnothing 35$ mm (1 2/5"), Width: 70 mm, Length: 70 mm. ~ 0,3 kg (0,65 lbs)	 <b>KNIFE TYPE XII</b> Max. diameter of branches to be cut: $\varnothing 15$ mm (0,6"), Width: 75 mm, Length: 122 mm. ~ 0,3 kg (0,65 lbs)

FLAIL KNIFE TYPES		
TYPE	STANDARD	OPTION
PIKO	X	VII, VIII
MIDO	V	II, III, IV
VINO	VI	
NANO HYDRO	X	VII, VIII
GRINO	V	II, III, IV
MAMUT	VI	III, IV
KANGU	V	II, III, IV
KBRP	I	II, III, IV
LAMA	V*, VII	VIII, IX
KW	I	II, III, IV
IBIS	VII	IX, XI, XII

## Flail mowers

PIKO 100, PIKO 130, PIKO 150 LIGHT CLASS



Light flail mower PIKO is designed for mowing squares, pitches, lawns, road shoulders or parks. After mowing it leaves even and smooth surface. Thanks to its design, application of strong bearings with their effective sealing system as well as use of highly durable materials, mower is a problem-free machine. It's light, strong and durable design provides long-lasting and reliable operation. Hydraulic side shift option (H-models) allows for shifting from one side to another, which therefore allows for obstacle passing.

### Characteristics:

- PIKO mower is designed for mowing squares, pitches, road shoulders or parks, in general works of moderate congestion.
- Is used for levelling molehills, mowing, shredding grass and weeds, which if scattered over, putrefy and fertilize green areas.

### Advantages:

- side-shift for 32 cm (1'1") possible (option)
- front or rear mounting possible
- bearing protection and lubrication system
- highly durable inner shell, made of hard-wearing steel
- low noise operation
- flail knives are easy to replace on site
- perfect ground following and even cutting height
- gearbox with overrunning clutch as standard



PIKO 100

## Flail mowers

NANO 150 HYDRO MEDIUM CLASS



NANO lightweight flail mowers have a specially designed suspension system for self propelled mowers and garden tractors. Design of rocker hitch assembly enables to wide range of ground contour following in 3 dimensions.

### Standard equipment of NANO 150:

- flail shaft with spiral arrangement of flails (double overlapping)
- hitch for garden tractors
- adjustable ground following wheels
- ground following bar
- hardened sliding skids
- automatic V-belts tensioning
- mowing height adjustment with ground following bar
- adjustable support leg
- replaceable counter-knives
- PTO shaft

### Standard equipment of NANO 150 HYDRO:

- flail shaft with spiral arrangement of flails (double overlapping)
- hydraulic motor (three at choice)
- rocker hitch
- adjustable ground following wheels
- ground following bar
- hardened sliding skids
- mechanical transport protection
- automatic V-belts tensioning
- mowing height adjustment with ground following bar
- replaceable counter-knives

### ADVANTAGES OF NANO FLAIL MOWERS:

#### Design

- rocker hitch assembly enables great ground contour following in 3 dimensions
- wide range of mounting frames allows for quick attachment

#### low weight thanks to high quality steel

#### Ground following bar

- self-cleaning with flails

#### no pressing of cut material

#### Flail shaft

- equipped with double row barrel bearings
- arrangement of flails provides intensive shredding of material, faster drying and decomposition



NANO 150



NANO 150 HYDRO

# Flail mowers

MIDO 140, MIDO 160, MIDO 180, MIDO 200, MIDO 220 MEDIUM CLASS



MIDO lightweight flail mowers are available in 1.4 m to 2.2 m (4'7" to 7'2") working widths. They are widely used in plants and companies involved in the maintenance of green areas and roads. They ensure effective mowing and mulching of grass, weeds, scrubs, preparing the area for future development. MIDO is characterised by low weight, high durability, efficiency and convenient aggregation. The different sizes and the front and rear mounting adjustment mechanism allow the machine to be perfectly suited to the terrain conditions. The mower can be aggregated to the three-point linkage cat. I or II. The recommended tractor power depends on the model and ranges from 45 hp to 80 hp.

## Standard equipment:

shaft with double flail spiral (double overlapping) • one-sided headstock (reversible rear / front) • overrunning clutch integrated in the gearbox • automatic tensioning of V-belts • hardened sliding skids • protective metal guards • replaceable counter-knives • mowing height adjustment with ground following bar • PTO shaft • flails at choice

## Advantages:

- gearbox with a freewheel for safety and easy use of the machine
- the wide range of working widths and the possibility of using different types of blades allows the machine to be adapted to the working conditions and the type of terrain to be mown
- lightweight, compact design and at the same time high efficiency ensure economical use
- two rows of replaceable and adjustable counter-blades guarantee a more accurate mowing
- the body made of extremely durable and wear-resistant ROC 400 steel significantly extends the service life of the machine
- the double-covered body guarantees durability
- the belt drive ensures quiet operation of the machine



NANO 140



## Flail mowers

VINO 160, 180 **REAR-FRONT** MEDIUM CLASS



The VINO lightweight flail mower provides effective and intensive mulching of branches and grass, so it is ideal for wine-growing and horticulture. Low weight, high durability, excellent ground tracking and high productivity are the main advantages of the machine. Precisely designed flails' system in the shaft thoroughly mulches the material speeding up the drying and decomposition processes. The machine has been equipped

### Standard equipment:

shaft with double flail spiral (double overlapping) • one-sided headstock (reversible rear / front) • overrunning clutch integrated in the gearbox • automatic belt tensioning • hardened sliding skids • protective metal sheet guards • replaceable counter-knives • mowing height adjustment with ground following bar • PTO shaft • flails at choice



with a double, adjustable rake to increase its effectiveness, feeding the flail roller zone with plant and shoot residues that require more intensive milling. The mower during the mulching does not damage fragile plants in the vicinity. The VINO 180 is suitable for tractors with a power not less than 60 HP and has the possibility of connecting to the three-point linkage cat. I or II.

### Advantages:

- the shaft has two selectable positions and removable rake teeth that enable the machine to operate in the standard mulching system as well as in a more intensive mulching system suitable for fruit-growing
- belt drive with freewheel protects the machine against damage when the shaft is blocked and hits an obstacle and ensures quiet operation
- narrow (2,95 cm) and shaped cover eliminates the risk of damaging fragile plants in the vicinity
- ground tracking shaft with adjustable working height for perfect ground tracking and increased stability during work
- the modular design of the machine makes it possible to choose from three types of hooks, which proves its flexibility and convenience of use
- lightweight yet robust design made of durable and wear-resistant ROC 400 steel
- enables to use the roller self-cleaning function when working without rake
- specially adjustable scraper ensures that the roller is cleaned when working with rakes and prevents foreign bodies from being thrown out of the machine

## Flail mowers

KANGU 140, KANGU 190, KANGU 220 **REAR-SIDE** MEDIUM CLASS



Kangu mowers are to be mounted on rear 3-point hitch (cat. II). The driveline is powered by the PTO shaft. Mower is additionally equipped with cross-shift option to provide comfortable obstacle passing and easier overlap adjustment.

### Standard equipment:

shaft with double flail spiral (double overlapping) • overrunning clutch integrated with gearbox • mechanical safety breakaway device • mowing height adjustment with ground following bar • rear rubber guard • front metal sheet guard • wide-angle PTO shaft • automatic tensioning of V-belts

### Characteristics:

1. Medium class flail mower especially designed for road shoulder and green area (orchards, vineyards) maintenance.

### Advantages:

- inner-skin of mower's shell, made of hard-wearing steel
- mower is to be mounted on 3-point hitch
- thanks to a parallelogram arm mowing is possible in various positions
- hydraulic control as standard
- side shift of 113 cm possible
- innovative bearing protection and lubrication system
- perfect ground following for optimal mowing quality
- mechanical safety breakaway device as standard
- gearbox with integrated clutch
- wide angle PTO shaft as standard

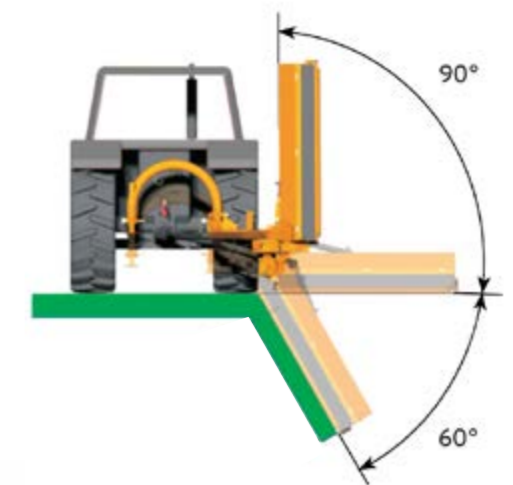

High angle of operation from 60° to 90° allows working on slopes.



# Flail mowers on parallelogram arm

KBRP 160, KBRP 200 **REAR-SIDE** HEAVY DUTY CLASS



# Flail mowers



KBRP rear-side mowers on parallelogram arm, complement our offer of heavy-duty machines. Especially designed for carriageway maintenance, green belts, road shoulders or ditches. These machines meet both, agricultural as well as municipal service demands. Hydraulic cylinder's choke valve enables smooth operation.

### Advantages:

- KBRP mowers feature high horizontal reach, up to 170 cm (5'7") which enables easy obstacle passing (e.g. road signs) without changing tractor's position
- possibility of working in-line or at side of the tractor
- thick-walled flail shaft's tube with diameter of 168 mm (6 3/5")
- mechanical safety breakaway devices as standard
- heavy-duty forged flail knives
- reinforced flail shaft's housing and bearings located internally are well protected against mechanical damage
- possibility of working within the inclination of + 90° and -60°
- owing to the parallelogram arm works perfectly for heavy-duty road maintenance assignments
- mower is to be mounted on 3-point hitch
- perfect ground following and high mowing quality
- gearbox equipped with overrunning clutch
- wide angle PTO shaft

### Standard equipment:

shaft with double flail spiral (double overlapping) • mechanical safety breakaway device • mowing height adjustment with ground following bar • rear rubber guard • front metal sheet guard • wide-angle PTO shaft • automatic tensioning of V-belts

### KBRP mowers have two mechanical safety devices:

- enables rise of the machine when obstacle is met
- enables retraction of the machine when obstacle is hit

### Characteristics:

- cutting scrubs and bushes (up to 8 cm/0'3" in diameter)
- mowing of scarps, embankments, drainage ditches and water canals



High manufacturing quality and exceptional durability of components ensure reliable and longlasting operation. Down-tilt angle can reach up to 60°, which is perfect whenever road shoulders and slopes need to be mowed (tilt angle between -60°; +90°). Mowers equipped with type I knives are able to shred branches with diameter up to 8 cm (3 1/5").

KBRP mulchers with pantograph meet the expectations of both municipal companies and farmers providing services of mowing roadside green belts, scarps, embankments, drainage ditches and water canals. The mowers are equipped with a new, stronger flail roller bearing system. The bearings are placed inside the support frame, which prevents mechanical damage.

KBRP with parallelogram arm, enables operation in-line or at the side of the tractor.

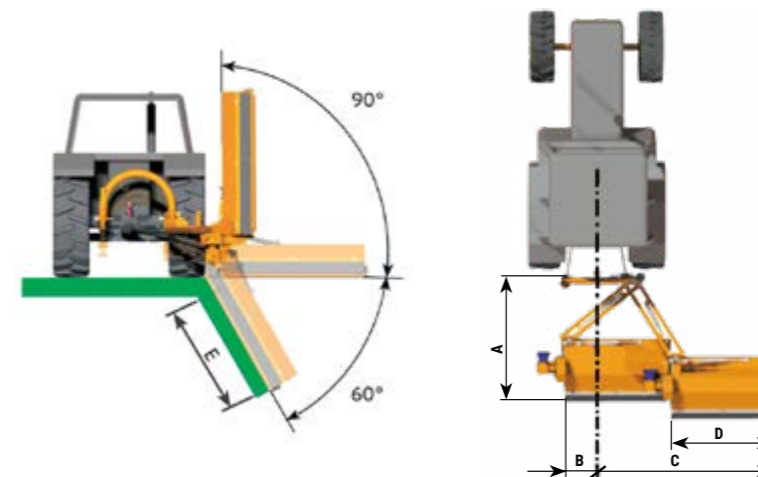

Horizontal work reach of KBRP mowers [ft]					
Type	A	B	C	D	E
KBRP 160	6'8"	1'8"	9'5"	5'4"	4'0"
KBRP 200	6'8"	1'8"	10'9"	6'8"	4'0"

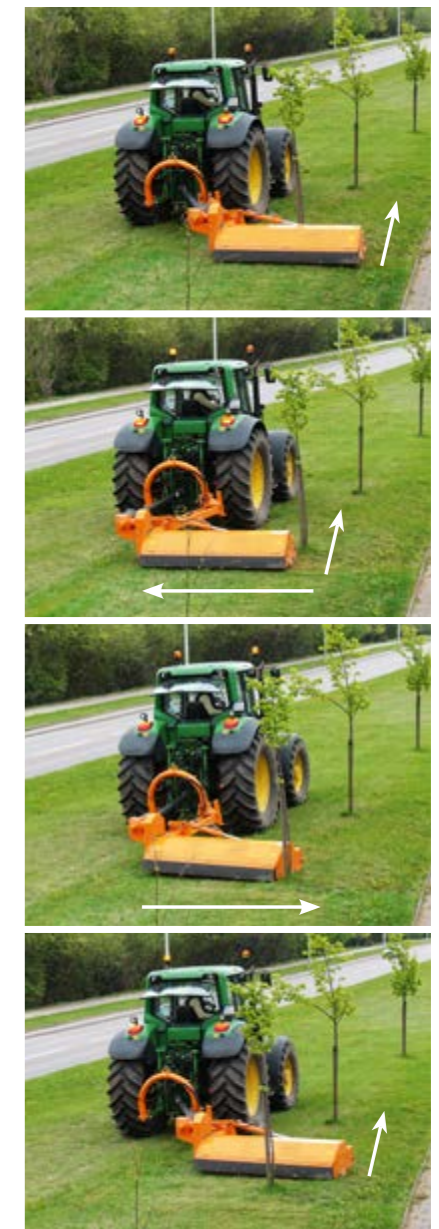

## Flail mowers

GRINO 160, GRINO 180, GRINO 200, GRINO 220  
**REAR-FRONT HEAVY DUTY CLASS**



GRINO mower can be typically aggregated with tractors with 3-point hitch of Cat. I or II. Flail shaft is driven by the PTO shaft, while the side-shift by tractor's hydraulics. Mower can be mounted either on tractor's front or rear, which improves general

work comfort. Advantages of GRINO mowers as compared to old KB mowers, are the following: hydraulic side-shift as standard feature, replaceable counter-knives made of hardened steel, larger number of cutting knives ensuring good shredding.

### Standard equipment:

shaft with double flail spiral (double overlapping) • overrunning clutch integrated in gearbox • mowing height adjustment with ground following bar • hardened sliding skids • protective metal guards • replaceable counter-knives • PTO shaft • automatic tensioning of V-belts • hydraulic side shift

### Characteristics:

- mowing shrubs and bushes, shredding branches of max. diameter of 2"
- cutting weeds and grass on uncultivated areas, treatment of sterile pastures and operation on green areas (orchards, vineyards)



## Flail mowers



### Advantages:

- balanced weight (0.7 kg / 1.55 lbs) and precise helical arrangement of flail knives provide effective operation in difficult conditions
- large diameter of flail shaft (ø 168 mm / 6 3/5") improves its durability and peripheral speed of flail knives
- mounting on 3-point hitch at the front or rear of the tractor
- easy, on-site, flail knife replacement
- low noise operation
- perfect ground following and even cutting height
- metal plate guards at the front and rubber guard at the back provide effective protection against stones
- working height adjustment within the range of 3 to 8 cm (1 1/5" to 3 1/5")
- reinforced flail shaft's housing and bearings located internally

- replaceable sliding skids made of hard-wearing steel
- additional skin of hard-wearing steel on the whole inner side of mower's shell
- gearbox equipped with overrunning clutch
- bearing protection and lubrication system
- side-shift for 1' 19" possible
- PTO shaft as standard

### Characteristics:

- 1 In order to mount the mower at the front-link, put upper arm on the opposite side of the machine and re-install the PTO shaft. If tractor features anti-clockwise rotation of the PTO, dismount central gearbox and turn it around by 180°
- 2 Enhanced housing has been designed to provide effective protection of bearings against dirt and debris
- 3 Side-shift by means of hydraulic cylinder as a standard feature
- 4 Belt gear drive transmission functions as overload clutch





# Flail mowers

MAMUT 250, MAMUT 280, MAMUT 300 REAR-FRONT  
SUPER HEAVY DUTY CLASS



Mamut, typically can be aggregated on 3-point hitch Cat. II. Flail shaft is powered by the PTO shaft. Mower can be mounted at the front or rear of the tractor, which improves general

comfort of operation. Mower is additionally equipped with side-shift option to provide comfortable obstacle passing and easier overlap adjustment.

### Standard equipment:

shaft with double flail spiral (double overlapping) • overrunning clutch integrated in gearbox • hydraulic side shift • double-shell body • mowing height adjustment with ground following bar • hardened sliding skids • adjustable support stands • protective metal sheet guards • replaceable counter-knives • PTO shaft • automatic tensioning of V-belts • flails at choice

### Characteristics:

- Heavy duty flail mower is designed for mulching soil fertilisation plants (lupinus, phacelia, sinapis, rapeseed, field pea, rye) before the tillage. As well as difficult to plough plant remains, like thick corn stalks.
- It is also used for pasture and uncultivated area maintenance.

### Hydraulic side shift:



# Flail mowers



### Advantages:

- side-shift for 50 cm (1' 19") possible
- large working efficiency
- front mount possible
- large diameter of flail shaft 8" improves its durability and peripheral knife speed
- bearing protection and lubrication system
- Two-skin steel shell. Inner layer made of hard-wearing material, which significantly improves durability and wear resistance
- heavy-duty forged flail knives
- perfect ground following and even cutting height
- gearbox equipped with overrunning clutch
- PTO shaft as standard



## Flail mowers

MAMUT 860 TWIN REAR-TWO SIDED SUPER HEAVY DUTY CLASS

NEW!



The MAMUT 860 TWIN double-sided flail mower is a combination of innovation, efficiency and mowing precision. Specially designed hydraulic block enables operation of all the machine functions with tractor hydraulic remotes without any additional valves or control panel. The indicator of the wanted three-point hitch height makes it easier to set up the machine for work. Stepless working width adjustment, controlled from the tractor's cab, allows to set the overlap of front mower with rear working units from 10 cm to 40 cm (4" - 15 3/4"). Flail shaft has been designed to maximize the efficiency of mowing. Spiral

arrangement of flails and double overlapping provide intensive shredding of material and faster decomposition. Ground following bar has a working height adjustment and thanks to its design ensures high stability during operation. Self-cleaning of the ground following bar improves the comfort of working. The body of MAMUT 860 TWIN is made of high quality steel which is resistant to abrasion.

### Standard equipment:

- flail shaft with spiral arrangement of flails (double overlapping)
- ground following bar
- intersecting gearbox with built-in clutch
- hydropneumatic suspension system
- hydraulic side shift
- hardened sliding skids
- replaceable inner mantle
- front protective metal flaps
- automatic tensioning of V-belts
- mowing height adjustment with ground following bar
- KENNFIXX grips
- adjustable support stands
- replaceable counter-knives
- PTO shaft

### Additional equipment:

- Ground following wheels
- Front protective chains
- Second row of counter-knives
- Working lights
- Adapter for ground following bar mounting outside the housing



## Flail mowers

KBR 120 L, KBR 140 L REAR-SIDE LIGHT CLASS

NEW!



Series of SaMASZ rear-side flail mowers KBR L extend the offer of light class machines. Mowers of this type are used for green areas and roadsides maintenance.

Ground following bar mounted in the mower has working height adjustment, which defines the cutting height. This bar also increases the stability during operation and ensures no pressing of cut material. Self-cleaning of ground following bar with flails improves the comfort of working.

### Standard equipment:

- Hydraulic cylinder
- Safety breakaway device
- Mowing height adjustment with ground following bar
- Rear rubber cover
- Adjustable hitch pins
- Front protective plastic flaps
- Adjustable support stand
- PTO shaft
- Automatic V-belts tensioning

### Additional equipment:

- Front protective chains
- Inner mantle
- Front protective metal flaps

### Advantages:

#### Design

- enables work within  $-65^{\circ}$  to  $+90^{\circ}$
- body made of high-class steel
- overrunning clutch built in a PTO shaft
- front protective plastic flaps

#### Ground following bar

- self-cleaning with flails
- no pressing of cut material

#### Flail shaft

- equipped with double row barrel bearings
- arrangement of flails provides intensive shredding and quicker decomposition of mowed material
- combined with front flail mower ensures less drives, and time savings as a result



# Flail mowers

IBIS 150, IBIS 150 UP **REAR-FRONT**  
SUPER HEAVY DUTY CLASS



Introduction of IBIS flail mowers, extended the range of mulchers with a tank. IBIS series flail mowers are designed for surfaces requiring special care, such as golf or football courses. These are the areas where the total weight of the whole set plays an important role – its own weight does not exceed 904 lbs. The UP version allows the contents of the collection hopper to be unloaded directly onto the trailer. The maximum height of unloading is 6'7"/2.00 m.

#### Standard equipment:

- shaft with double flail spiral (double overlapping)
- hydraulic discharge
- mowing height adjustment
- road lights
- PTO shaft
- front support wheels set (IBIS)
- automatic tensioning of V-belts

#### Advantages of flail mowers with collection hoppers:

- simultaneous mowing and material collection
- hydraulic unloading
- designed for low power tractors
- low weight due to the use of high-quality steel
- accurate ground tracking and stepless cutting height adjustment
- mulching scrubs, bushes and sticks, collection of leaves in autumn

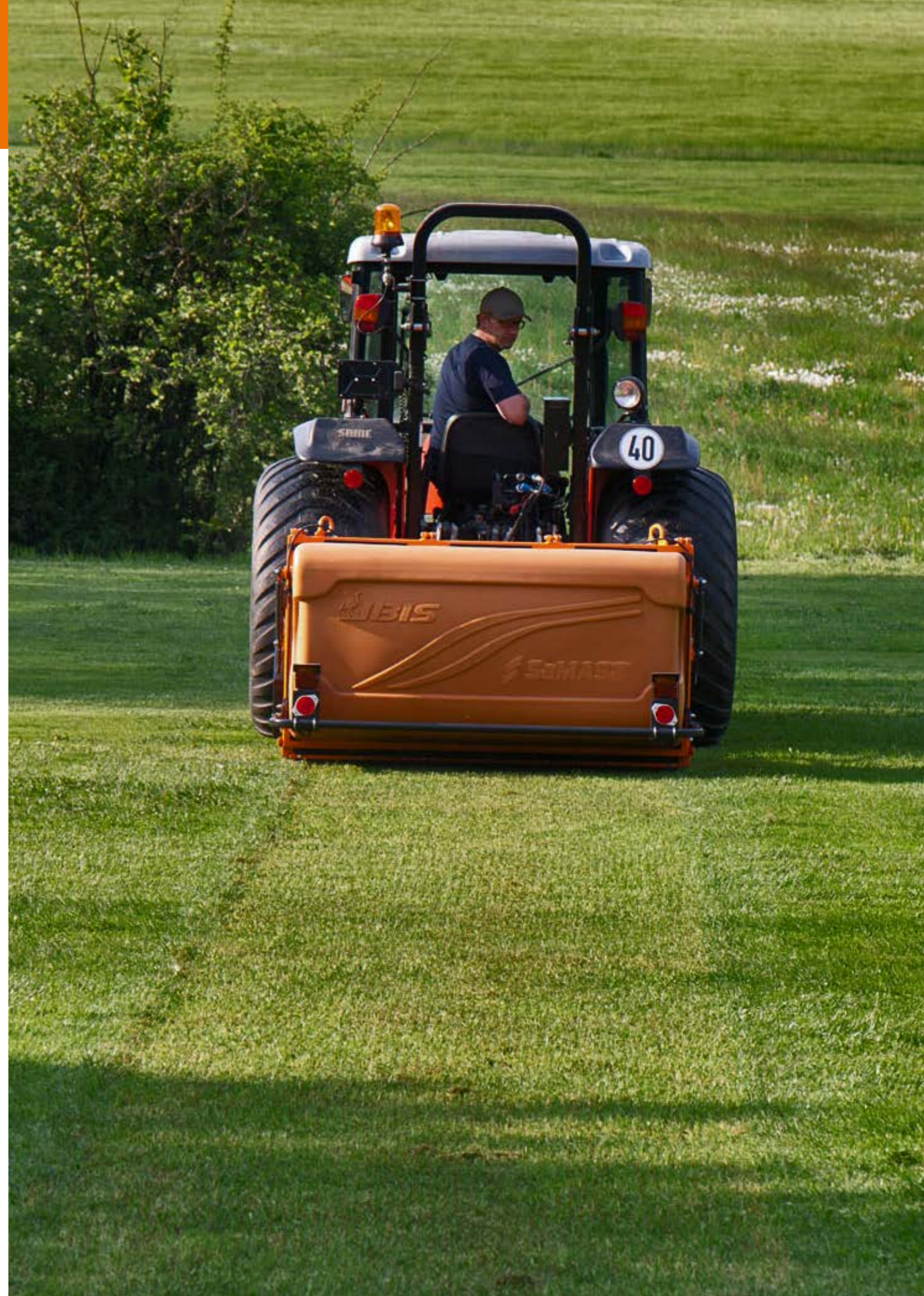

# Extension arms

KOLIBER 400, KOLIBER 450 REAR

Light-weight, compact, durable



KOLIBER extension arm, with work reach of 13'1/4m or 14'9/4,5m is to be mounted at tractor's 3-point hitch. Arm is equipped with a hydraulic unit, made by a well-known manufacturer. Oil tank capacity of 31,70 gal, radiator and cable control panel are fitted as a standard feature.

### Advantages:

- low weight enables mounting on a light-weight tractors
- innovative design
- high arm clearance enables safe drive over road signs and easy obstacle passing.

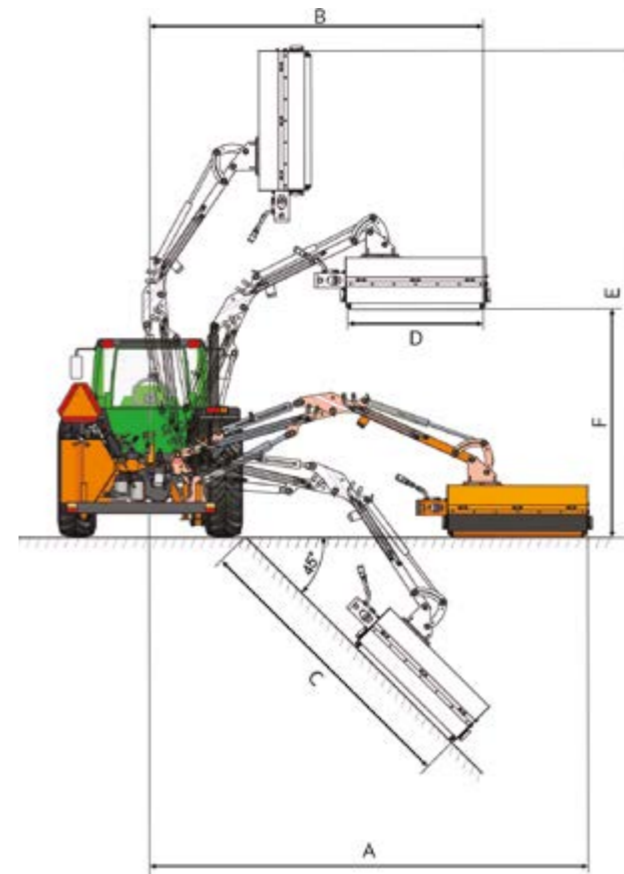

Work reach of KOLIBER 400 extension arm with LAMA 120 [cm] mowing head

Type	A	B	C	D	E	F
Koliber 400	410	310	270	120	455	220
Koliber 450	460	350	320	120	505	250

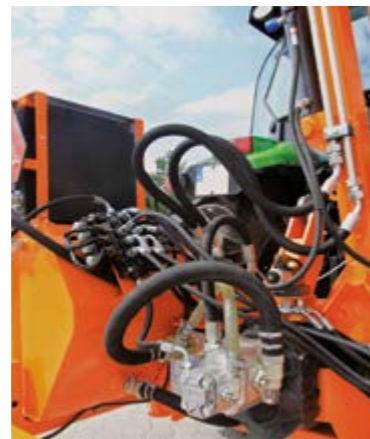
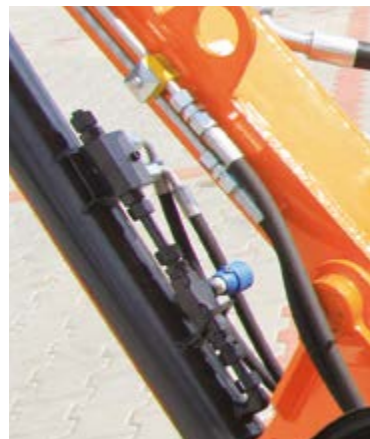

Hydraulic latch on main cylinder together with adjustable choke valve.

Hydraulic assembly with multi-block selector valves - durable and efficient.

Unit in transport position - rear bumper with noticeable road lights.

### Standard equipment:

hydraulic cylinders • mechanical safety breakaway device • cable control panel • temperature and oil level indicator • hydraulic lock • oil radiator with oil filters • choke valves on hydraulic cylinders • road lights PTO shaft

### Optional equipment:

• electronic control panel together with electric control system  
• 1000 rpm PTO

# Extension arms

KWT 550, KWT 650, KWT 651 E/EP **REAR**



# For hard to reach locations



KWT extension arm is available in two versions - with reach of 18'5,5m and 21'4"/6,5m. Is to be mounted on 3-point hitch (Cat. II). KWT 650 in contrast to KWT 550 has a hydraulically driven, extendable telescopic dipper arm. Machine is equipped with independent hydraulic unit with radiator and 180 l oil tank. In the latest KWT 651 model, an arm can be directed to the side of the tractor, which provides better visibility of working head and improves work comfort.

### Advantages:

- quick and easy attachment exchange
- own, independent hydraulic system
- standard, 3-point hitch mounting (Cat. II)
- hydraulic safety breakaway device as standard
- applied choke valves allow for stepless and precise adjustment of arm's rotation speed
- high durability of the unit
- temperature and oil level indicator
- high work reach up to 21'10"/6,65m (KWT 650 with mowing head KW 140)



### Standard equipment:

hydraulic cylinders • hydraulic safety device • cable control panel • temperature and oil level indicator • hydraulic lock • radiator with oil filters • choke valves on hydraulic cylinders • PTO shaft



Within the hydraulic system, an oil radiator is installed which protects the unit from overheating.



Oil filters with a soil gauge are installed in the hydraulic system for additional protection.



Hydraulic safety device protects the machine from damage - in the event of an obstacle collision - the arm tilts back.



Additional stop valve protects the arm from falling even if hydraulic hose gets damaged.

### Work reach of KWT 651 E arm together with mowing head LAMA 121

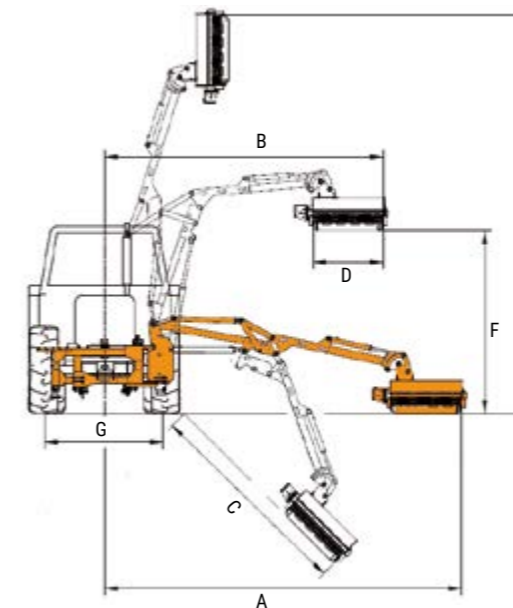
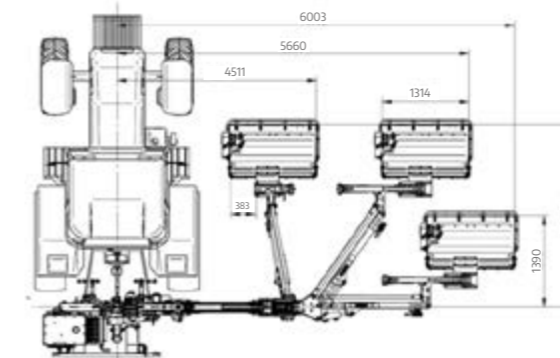

As standard the control of the arm is done with the use of cable control panel, equipped with levers and a joystick.

Control panel with joystick (Electric control) – standard: KWT 651  
Control panel with joystick (Electric control) – option: KWT 550 and KWT 650

Work reach of KWT arms together with mowing head [ft]

Arm/Head	A	B	C	D	E	F	G
KWT 550 / KW 110	224,40	173,22	145,66	43,30	251,96	114,17	74,80
KWT 550 / KW 125	224,40	177,16	145,66	51,18	251,96	114,17	74,80
KWT 550 / KW 140	228,34	177,16	149,60	59,05	255,90	114,17	74,80
KWT 550 / Lama 120	228,34	177,16	145,66	47,24	255,90	114,17	74,80
KWT 550 / Lama 140	236,22	185,03	153,54	55,11	263,77	114,17	74,80
KWT 650 / KW 110	259,84	208,66	181,10	43,30	283,46	118,11	74,80
KWT 650 / KW 125	259,84	208,66	181,10	51,18	283,46	118,11	74,80
KWT 650 / KW 140	265,74	212,59	185,03	59,05	287,40	118,11	74,80
KWT 650 / Lama 120	263,77	212,59	183,07	47,24	287,40	118,11	74,80
KWT 650 / Lama 140	271,65	220,47	190,94	55,11	295,27	118,11	74,80
KWT 651 E / KW 110	246,06	208,66	161,41	43,30	283,46	118,11	74,80
KWT 651 E / KW 125	246,06	208,66	161,41	51,18	283,46	118,11	74,80
KWT 651 E / KW 140	250	212,59	165,35	59,05	287,40	118,11	74,80
KWT 651 E / Lama 120	248,03	212,59	163,38	47,24	287,40	118,11	74,80
KWT 651 E / Lama 140	255,90	220,47	171,25	55,11	295,27	118,11	74,80

# Extension arms

CAMEL 900 REAR



# For hard to reach locations



Camel extension arm, with it's 29'7"/9m range is the largest machine of such type in Poland! Machine has a hydraulically driven, extendable telescopic dipper arms. Machine is equipped with independent hydraulic unit with radiator and 47,5 gal oil tank.



**Proportional steering (EP) available in option:**

- arm motion speed dependent on joystick position
- simultaneous two cylinder control possible

**Transport position:**



**Advantages:**

- high work reach of 29'7"/9m (with Lama 120)
- own reliable hydraulic system
- high durability of the unit
- applied choke valves allow for stepless and precise adjustment of arm's rotation speed
- additional hitch stabilizing links as standard



Range	[cm]
A	900
B	690
C	650
D	120
E	960
F	520

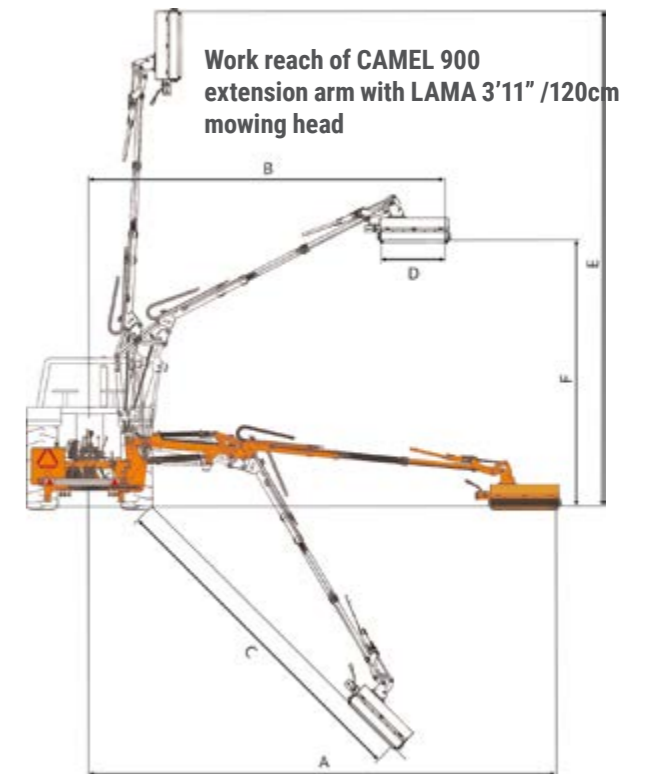

**Standard equipment:**

- hydraulic cylinders
- hydraulic safety breakaway device
- cable control panel
- temperature and oil level indicator
- hydraulic lock
- oil radiator with oil filters
- hydraulic cylinders with choke valves
- PTO shaft

**Optional equipment:**

- proportional control system
- PTO 1000 rpm



## Mowing head

Lama 120, Lama 121, Lama 121 HD, Lama 140, Lama 141, Lama 101P, Lama 121P  
KW 110, KW 125, KW 140, KW 111, KW 126, KW 141



### Lama 140

- 24 knives mounted on shackles
- light flail
- overall weight 451lbs
- flail shaft d 4 1/4"/10 cm
- ground following shaft d 133x5 mm
- external shell of 3 mm in thickness, made of hard-wearing steel



### Lama 141

- 24 knives mounted on shackles
- motor installed on the head to improve mowing of ditch bottoms
- drive transmission through V-belts
- arm mounting plate moved to the machine's back to improve arrangement of the centre of gravity, what in turn makes the machine more stable
- new position of the mounting plate enables the head to be moved mechanically in the horizontal
- head's safety barrier



### KW 140

- 12 knives mounted on bolts
- heavy flail
- overall weight 727 lbs
- flail shaft d 5 1/4"/12,7 cm
- ground following shaft d 168x6.3 mm
- external shell of 4 mm in thickness, made of structural steel

## Ditch cleaner / Trunk grinder

OR 080, FP 20



### DITCH CLEANER - OR 080



Designed for roadside or field ditch cleansing and profiling.

### TRUNK GRINDER - FP 20



Designed for tree-trunk grinding.

## Hydraulic extension arm / Circular saw

FISHER, PT3 - 190, PT4 - 250, PT3 - 190 F, PT4 - 250 F



### HYDRAULIC EXTENSION ARM - FISHER



FISHER extension arm is a telescopic jib designed to operate with circular saw PT3-190, PT4-250 as well as scissor trimmer PG 150, PG-200.

### CIRCULAR SAW - PT3 - 190, PT4 - 250, PT3 - 190 F, PT4 - 250 F

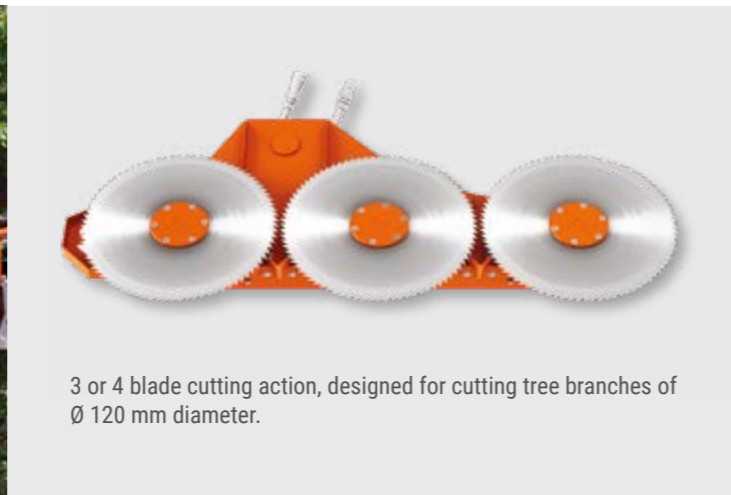

3 or 4 blade cutting action, designed for cutting tree branches of Ø 120 mm diameter.

## Scissor trimmer / Road shoulder grinder

PG 150, PG 200, PG 150F, PG 200F, RP 110,



### SCISSOR TRIMMER - PG 150, PG 200, PG 150F, PG 200F



Designed for vertical and horizontal trimming of branches, bushes and hedges.

### ROAD SHOULDER GRINDER - RP 110



Designed for leveling and profiling of road shoulders to provide proper drainage.



# Technical data

## Flail mowers

### Flail mowers

PIKO 100, PIKO 130, PIKO 150

Type	Working width [m / ft]	Working capacity [ha/h]	Number of knives [pcs.]	Flail shaft diameter [mm / in]	Power demand [HP]*	PTO [rpm]	3-point hitch Cat.	Dimensions w / l / h [cm]	Weight [kg / lbs]
PIKO 100 / PIKO 100H	1,00 / 3'4"	~ 1,00	26	ø 108 / 4 1/4"	from 20	540	I	87 / 129 / 83	175 / 385 205 / 450
PIKO 130 / PIKO 130H	1,30 / 4'4"	~ 1,30	34		from 30			87 / 159 / 83	200 / 440 230 / 510
PIKO 150 / PIKO 150H	1,50 / 4'11"	~ 1,50	40		from 35			87 / 200 / 83	220 / 485 250 / 550

### Flail mowers

NANO 150 HYDRO MEDIUM CLASS MEDIUM CLASS

Type	Working width [m / ft]	Necessary hydraulic couplers	Number of knives [pcs.]	Pump efficiency [l/min] / [GPM]	Power demand [HP]	Flail shaft diameter [mm / in]	3-point hitch Cat.	Dimensions w / l / h [cm]	Weight [kg]
NANO 150 HYDRO	1,50 / 4'11"	1 x double acting + leakage connector	40	32 / 40 or 50 (depends on engine choice)	from 35	108 / 4 1/4"	I	87 / 200 / 83	205 / 450

### Flail mowers

MIDO 140, MIDO 160, MIDO 180, MIDO 200, MIDO 220

Type	Working width [m / ft]	Number of replaceable counter-knives	Number of knives [pcs.]	Flail shaft diameter [mm / in]	Power demand [HP]	PTO [rpm]	3-point hitch Cat.	Max. diameter of branches to be cut [mm]	Weight [kg / lbs]
MIDO 140	1,40 / 4'7"	2 rows	18	ø 108 / 4 1/4"	from 45	540	I / II	35	370 / 815
MIDO 160	1,60 / 5'3"		20	from 50	415 / 915				
MIDO 180	1,80 / 5'11"		22	ø 133	from 60			435 / 960	
MIDO 200	2,00 / 6'7"		24	from 70	450 / 992				
MIDO 220	2,20 / 7'2"		26	ø 139	from 80			480 / 1 058	

### Flail mowers

VINO 160, VINO 180

Type	Working width [m / ft]	Number of knives [pcs.]	Number of replaceable counter-knives [pcs.]	Number of V-belts	Power demand [HP]	Flail shaft diameter [mm / in]	3-point hitch Cat.	Dimensions w / l / h [cm]	Weight [kg / lbs]
VINO 160	1,60 / 5'3"	18	2	1	from 50	133 / 5,23	I / II	180 / 100 / 100	355 / 782
VINO 180	1,80 / 5'11"	20	2	1	from 60	133 / 5,23	I / II	200 / 100 / 100	380 / 837

### Flail mowers

KANGU 140, KANGU 190, KANGU 220

Type	Working width [m / ft]	Necessary hydraulic couplers	Number of counter knives	Number of knives [pcs.]*	Flail shaft diameter [mm]	Power demand [HP]**	RPM	3-point hitch Cat.	Max. diameter of branches to be cut [mm / in]	Weight [kg / lbs]	PTO shaft
KANGU 140	1,40 / 4'7"	2 x double acting	1 row / 2 pcs.°	24	ø 133 / 5 15/64"	from 50	540	II	50 / 2"	540 / 1 190	tractor - mower: wide-angle (overrunning clutch in gearbox)
KANGU 190	1,90 / 6'3"			30	ø 133 / 5 15/64"	from 70				660 / 1 455	
KANGU 220	2,20 / 7'2"			32	ø 139 / 5 1/2"	from 85				775 / 1 664	

\* Types of flail knives, standard and optional on page 5

\*\* Note! Power values apply only to municipal works - few mowing occasions per year.

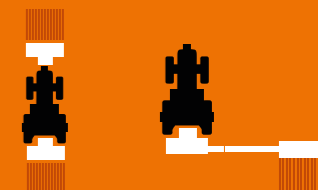

### Flail mowers

KBRP 160, KBRP 200

Type	Operating width [m / ft]	Necessary hydraulic couplers	Number of counter knives	Range of work	Knives [pcs.]*	Flail shaft diameter [mm]	Power demand [HP]**	RPM	3-point hitch cat.	Weight [kg / lbs]	Max. diameter of branches to be cut [mm / in]	PTO shaft
KBRP 160	1,60 / 5'3"	2 x double acting	1 x fixed	from -60° to +90°	14 (18-option)	ø 168 / 6 39/64"	from 70	540	II	760 / 1 675	80 // 3 5/32"	tractor - mower: wide-angle with overload clutch
KBRP 200	2,00 / 6'7"				16 (24-option)		from 80			825 / 1 818		

### Flail mowers

GRINO 160, GRINO 180, GRINO 200, GRINO 220

Type	Working width [m / ft]	Working capacity [ha/h]	Number of knives [pcs.]*	Flail shaft diameter [mm / in]	Power demand [HP]	PTO [rpm]**	3-point hitch Cat.	Dimensions w / l / h [cm]	Weight [kg / lbs]
GRINO 160	1,60 / 5'3"	~ 1,50	24	ø 168 // 6 39/64"	from 50	540 / 1000	I / II	185 / 115 / 104	580 / 1 280
GRINO 180	1,80 / 5'11"	~ 1,60	24		from 60			205 / 115 / 104	610 / 1 345
GRINO 200	2,00 / 6'7"	~ 1,80	30		from 70			225 / 115 / 104	640 / 1 410
GRINO 220	2,20 / 7'2"	~ 2,00	36		from 80			245 / 115 / 104	665 / 1 470

\* Types of flail knives, standard and optional on page 5

\*\* The mower is factory set to 540 rpms. In case of front-link mounting the gearbox should be adapted to 1000 rpms

### Flail mowers

MAMUT 250, MAMUT 280, MAMUT 300

Type	Working width [m / ft]	Working capacity [ha/h]	Number of knives [pcs.]	Flail shaft diameter [mm]	Power demand [HP]	PTO [rpm]	3-point hitch Cat.	Dimensions w / l / h [cm]	Weight [kg / lbs]
MAMUT 250	2,50 / 6'6"	~ 2,50	30	ø 203 / 8"	from 100	1000	II	280 / 124 / 106	960 / 2 115
MAMUT 280	2,80 / 9'2"	~ 2,80	36		from 120			300 / 124 / 106	1050 / 2 315
MAMUT 300	3,00 / 9'8"	~ 3,00	36		320 / 124 / 106			1090 / 2 403	

### Flail mowers

IBIS 150, IBIS 150 UP

Type	Working width [m / ft]	Working capacity [ha/h]	Number of knives [pcs.]	Container capacity [m³ / cu.ft.]	Flail shaft diameter [mm]	Power demand [HP]	PTO [rpm]	3-point hitch Cat.	Dimensions w / l / h [cm]	Weight [kg / lbs]
IBIS 150	1,50 / 5'	~ 1,00	50	0,90 / 35	ø 108 / 4 1/4"	from 35	540	I	163 / 100 / 184	430 / 947
IBIS 150 UP									163 / 135 / 184	490 / 1080

# Technical data

## Extension arms / Moving heads

### Extension arms

PIKO 100, PIKO 130, PIKO 150

Type	Work reach [m / ft]	Power demand [HP]	Control	PTO [rpm]	Recommended tractor's weight [kg / lbs]	Transport width [cm / ft]	Transport height [cm / ft]	Weight [kg / lbs]
Koliber 400	4,0 / 13'1"	from 55	cable / electric on-off	540	2 400 / 5 290	175 / 5'9"	265 / 8'8"	530 / 1 170
Koliber 450	4,5 / 14'9"				2 900 / 6 395	185 / 6'1"	290 / 9'6"	580 / 1 280

### Extension arms

KWT 550, KWT 650, KWT 651 E/EP

Type	Arm's reach [m / ft]	Power demand [HP]	Tractor's weight [kg / lbs]	Control	PTO [min]	Transport width/height/length [m]	Weight [kg / lbs]
KWT 550	5,50 / 18'	from 80	3700 / 8 157	link	540	3,5 / 1,95 / 0,95	1 055 / 2 325
KWT 650	6,50 / 21'	from 90	4300 / 9 480				1140 / 2 513
KWT 651 E/EP	6,40 / 21'	from 90	4300 / 9 480	electric 0-1/proportional			1 230 / 2 710

### Extension arms

CAMEL 900

Type	Work reach [m / ft]	Control	PTO [rpm]	Recommended tractor's weight [kg / lbs]	Transport width [cm / ft]	Transport height [cm / ft]	Weight [kg / lbs]
Camel 900	9,0 / 29'6"	link	540	7 500 / 16 534	190 / 6'2"	400 / 13'1"	1370 / 3 020

### Mowing heads

LAMA, KW

Typ	Lama 120	Lama 121	Lama 121 HD	Lama 140	Lama 141	Lama 101 P	Lama 121 P	KW 110	KW 125	KW 140	KW 111	KW 126	KW 141
Working width [m / ft]	1,20 / 3'11"	1,20 / 3'11"	1,20 / 3'11"	1,40 / 4'7"	1,40 / 4'7"	1,06 / 3'5"	1,20 / 3'11"	1,10 / 3'7"	1,25 / 4'1"	1,40 / 4'7"	1,10 / 3'7"	1,25 / 4'1"	1,40 / 4'7"
Flail knives*	20	20	20	24	24	30	34	10	10	12	12	14	16
Oil pump efficiency [l/min / GPM]	90 - 100 / 23 - 26							90 - 100 / 23 - 26					
Hydraulic pressure [bar / PSI]	210 / 3 045							210 / 3 045					
Weight [kg / lbs]	185 / 407	245 / 540	270 / 595	205 / 451	265 / 584	250 / 551	275 / 606	265 / 584	305 / 672	330 / 727	250 / 551	270 / 595	280 / 617
Flail shaft diameter [mm / in]	∅ 108 // 4 1/4"	∅ 108 // 4 1/4"	∅ 133 // 5 16/64"	∅ 108 // 4 1/4"	∅ 108 // 4 1/4"	∅ 108 // 4 1/4"		∅ 133 // 4 1/4"			∅ 133 // 5 1/4"		
Max. diameter of shredded sprout [mm / in]	35 // 1 3/8"	35 // 1 3/8"	35 // 1 3/8"	35 // 1 3/8"	35 // 1 3/8"	20 // 0 25/32"		35 // 1 3/8"			40 // 1 1/5"		
Arm type	KOLIBER, KWT, CAMEL	KWT, CAMEL	KWT	KOLIBER, KWT, CAMEL	KWT	KWT, CAMEL		KWT					

# Technical data

## Extension arms / Moving heads

### Ditch cleaner

OR 080

Type	OR 080
Working width [m / ft]	0,80 / 2'7"
Number of knives [pcs]	8
Number of throwing blades [pcs]	4
Oil pump efficiency [l/min / GPM]	80-100 / 21-26
Hydraulic pressure [bar / PSI]	210 / 3045
Weight [kg / lbs]	225 / 495
Arm type	KWT, CAMEL

### Stump grinder

FP 20

Type	FP 20
Working width [m / ft]	0,40 / 1'4"
Number of blades [pcs]	16
Oil pump efficiency [l/min / GPM]	70-100 / 18-26
Hydraulic pressure [bar / PSI]	210 / 3045
Weight [kg / lbs]	90 / 200
Arm type	KWT, CAMEL

### Hydraulic extension arm

OR 080

Type	FISHER
Side-shift [m / ft]	1,06 / 3'4"
Head rotation	110°
Necessary hydraulic couplers	1 x double acting 1 x single acting
Hydraulic pressure [bar / PSI]	210 / 3045
Weight with mounting frame [kg/lbs]**	250 / 550
Designation	PG F, PT F

### SCISSOR TRIMMER

PG

Type	PG 150	PG 150 F	PG 200	PG 200F
Operating width [m / ft]	1,50 / 4' 11"	1,50 / 4' 11"	2,00 / 6' 6"	2,00 / 6' 6"
Thickness of cut branches max [mm / ft]	100 / 4"			
Pump efficiency [L/min] / [GPM]	45-60 / 11-18			
Hydraulic pressure [bar / PSI]	160 / 2320			
Weight [kg / lbs]	200 / 440	200 / 440	240 / 530	240 / 530
Arm type	KWT, CAMEL	FISHER	KWT	FISHER

### Circular saw

PT

Type	PT3-190	PT3-190 F	PT4-250	PT4-250 F
Working width [m / ft]	1,90 / 6'3"	1,90 / 6'3"	2,50 / 8'2"	2,50 / 8'2"
Number of circular blades [pcs]	3	3	4	4
Circular blade diameter [mm / in]	630 / 25"			
Max. diameter of cut branches [mm / in]	∅ 120 / 5"			
Oil pump efficiency [l/min / GPM]	85-100 / 22-26	55 - 70 / 14-18	85-100 / 22-26	55 - 70 / 14-18
Weight [kg / lbs]	195 / 429	195 / 429	250 / 551	250 / 551
Arm type	KWT, CAMEL	FISHER	KWT, CAMEL	FISHER
Hydraulic pressure [bar / PSI]	180 / 2610			

### Road shoulder grinder

RP

Type	RP 110
Working width [m / ft]	1,20 / 3'11"
Flail shaft diameter [mm / ft]	∅ 168 // 6 3/5"
Oil pump efficiency [l/min / GPM]	70-100 / 18-26
Hydraulic pressure [bar / PSI]	210 / 3045
Weight [kg / lbs]	255 / 562
Arm type	KWT, CAMEL



**SaMASZ Sp. z o.o.**

**ul. Trawiasta 1  
16-060 Zabłudów  
Poland**

**tel.: +48 85 664 70 31  
e-mail: [export@samasz.pl](mailto:export@samasz.pl)**

**[www.samasz.com](http://www.samasz.com)**

Your dealer:



**Passion for work and constant search for the best solutions are ideas that have guided us from the beginning and have become the key to success.**

The main factors contributing to the dynamic development of the company are close contact with the client and openness to his needs. It is through partnership dialogue with our current and future customers, meeting their expectations and needs, that we create and strengthen the foundations for dynamic development.

With the goal of continuous development, we invest in research and development. We employ the most talented university graduates who are not only experts in their fields, but also bring professionalism and passion to what they do. You can always count on their competence and reliability.

Today SaMASZ is a leader in Poland and one of the leading European producers of green forage machines. Our offer includes over 300 types of different machines: disc mowers, tedders, rakes, mixer feeders, flail mowers, extension arms, snow plows and sweepers.

Production is currently carried out in Zabłudów (Podlaskie Voivodeship), in a new factory, launched in 2018, employing over 1000 people. SaMASZ dynamically develops export sales. About 65% of the company's production goes to over 60 countries around the world. The company's foreign branches are: SaMASZ North America LLC, SaMASZ BVBA Belgium - the Netherlands. The TOP 10 largest foreign markets are Germany, the United States of America, Canada, France, Ireland, Latvia, the Netherlands, Spain and Australia.

Our main goal is to constantly modernize and improve the design of our machines and to implement the highest technological achievements into the production processes in order to achieve world-class quality. We realize that in the face of changes taking place in the modern world, customers are looking for trustworthy business partners, which is why we have the ambition to be perceived as a recognized, reliable and professional manufacturer.



Technical data and equipment provided herein, as well as images of the products may be different due to constant technical development.